



CATALOGUE

GAS INSULATED SWITCHGEAR 123 kV

TYP **ZRNG**

Unser Handelspartner in Deutschland



ISO 9001:2009
ISO 14001:2005

ivep[®]

GENERAL INFORMATION

The tightly encapsulated ZRNG 123 switchboard is designed for use in 110 kV networks with effectively earthed zero point, in both the newly erected and retrofitted switchboard stations. Its small dimensions and the possibility of connection through a cable, or the overhead line or via encapsulated power lines make it an optimum means for use in switchboard stations installed directly in large industrial plants and in the inside of urban agglomerations.

The switchboard consists of a building block type of elements that provide for the possibility of setting up a large range of various wiring diagrams proposed by the designer, by adhering to all the requirements imposed on the equipment. The SF₆ gas insulation and a careful workmanship guarantee the high operation reliability of the system.

It is characterized especially by:

- - The elements of the switchgear are solved as kit what enables to build up the fields of the switchgear according to required diagram of connection.
- - The use of an electronegative gas SF₆ for insulation and extinguishing medium enables a considerable decrease of switchgear dimensions and especially an optimization of insulating system.
- - One-pole encapsulated system of devices and bus-bars guarantees a maximum service reliability and eliminates the origin of three-phase short-circuit. - All parts of the power circuit are protected against environmental influence.
- - The constructional and technologic solution guarantees that the gas leakage from encapsulation will be smaller than 1%/year.
- - The correct function of the equipment is given by the gas density not by the pressure of the gas which changes with the temperature. For this reason all separated gas spaces are equipped with temperature compensated pressure watcher.
- - The drop of gas pressure is signalled in two grades. The first grade signals the need to complete the SF₆ gas in the indicated space to the prescribed value. If the gas is not completed and the pressure drop continues, the second grade of signalling will operate.
- - The switchgear is protected by earth (chassis) protection in sections according to the agreement with the user which enables also to locate the place of the failure.
- - The material and the thickness of the encapsulation are selected so that at origin of indoor failure and at following arc short-circuit the destruction as well as the break through of the encapsulation does not occur till the action of the main protection.
- - The expansion of SF₆ gas pressure in the encapsulation is limited by destructional fuses which form part of each separated gas space.
- - The construction of the switchgear guarantees an inspectionless service during ten years.

ENCAPSULATION

The functional parts of single devices, instrument transformers, cable terminals, connecting parts and bus-bars are located in coverings casted from aluminium alloy or welded from aluminium semi-products. These coverings of cross or cylindrical shape are ended with flanges covered with aluminium or steel covers. The outdoor outlet is an exception at which the casing of the space filled with SF₆ forms a porcelain insulator.

The functions of the encapsulation are the following:

- separates the device located inside from outside influences (solar radiation, impurities, moisture)
- eliminates the gas leakage and ensures permanent insulating conditions
- creates the protection against dangerous contact

Inside protections of the switchgear

- Safety burst membrane

Every gastight space is equipped with destructional fuse (metal membrane) which eliminates the increase of pressure in encapsulation above permitted limit. The membrane is equipped with exhausts directed towards delimitate places where the operator as a rule does not move.

- Gas pressure scanner

Because the correct function of the insulating system depends on gas density not on its pressure which changes with temperature, the so called temperature compensated scanners of gas pressure with two grades of signalling are used. The first grade is set on pressure 0.418 ± 0.005 MPa and it signals the necessity to refill the gas. This refilling can be done only after a rather long time; the switchgear complies also with the testing voltage at this pressure from point of view of insulation. At decrease of pressure in the circuit breaker on a pressure of the second grade of signalling of 0.405 ± 0.005 MPa the function of the circuit breaker is blocked. The signal of the second grade at other parts of the switchgear can be used according to user's wish.

- Earth protection

The switchgear is equipped with earth protection for limitation of effects of contingent dielectric breakdown. The principle is based on quick indication of the fault current which flows between the encapsulation and the earth. The encapsulation of the switchgear is divided according to selected logic of effect of the protections on mutually separated spaces from point of view of insulation. These spaces are then connected by Cu-bands on which the transformer of earth protection with the earth is put on. The transformer has as a rule these parameters: ratio 400/5A, 10 VA, $n < 5$. The parameters depend on the earth protection logic.

SPECIFICATION

values of the encapsulated switchgear type ZRNG

Typ		ZRNG
Rated voltage	kV	123
Rated withstanding voltage at. impulse (1,2/50 μs)	kV	550
Rated withstanding voltage at. impulse (1,2/50 μs) in disconnected path of circuit breaker and disconnector	kV	630
Rated short-time withstanding alternating voltage (50 Hz/1 min)	kV	230
Rated short-time withstanding alternating voltage (50 Hz/1 min) in disconnected path of circuit breaker and disconnector	kV	265
Rated frequency	Hz	50
Rated current of outlet	A	1250
Rated current of bus-bars	A	1600
Rated short-time current 1s	kA	25
Short-time current 2s	kA	25
Rated dynamic current	kA	63
Rated work overpressure	MPa	0,35

Rated values of circuit breaker

Rated current	A	1600
Rated symmetrical breaking current	kA	25
rated making current	kA	63
rated switching cycle of circuit breaker		0-03 sec-CO-3 min-CO
Rated voltage of auxiliary circuits		60; 220 V DC 230 V AC

SWITCHGEAR

The switchgear ZRNG is one-pole tightly encapsulated switchgear insulated with SF₆ gas. It consists of switching devices, instrument transformers, bus-bars, inlet elements and connecting parts in unit-built configuration. All its parts are independently encapsulated and mutually connected by means of flanged connections equipped with sealing "O" rings.

The set of instruments is fixed on a supporting construction by means of a set of regulation elements which enable their correct assembly. The supporting construction is equipped with

four wheels which can be heightly adjusted. These wheels enable the movement of the switchgear on rails parallelly with the bus-bar system of the switchgear. The mechanical stress originating by dilatation of the bus-bar system at temperature changes is eliminated by this possibility of field movement of the switchgear.

The unit-built configuration enables the assembly of switchgear fields with one as well as two systems of bus-bars. It enables also the enlargement of already mounted switchgear on both ends without substantial disassembly of already mounted devices.

The switchgear field is divided by conical insulators in several mutually gas-tightly separated spaces. Single spaces are equipped with inlet valve, system of gas leakage indication and protection against dangerous increase of gas pressure. The encapsulation of corresponding spaces of single phases are mutually connected with earthing conductor which is connected on supporting construction of the field through the transformer of earth protection.

FIELD OF SWITCHGEAR

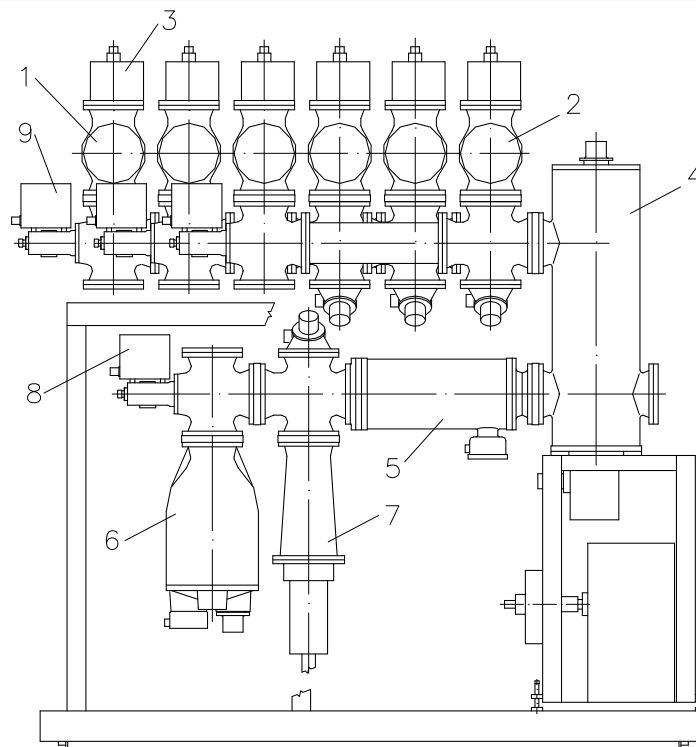

- 1,2 bus-bars
- 3 bus-bar disconnector
- 4 circuit breaker
- 5 instrument current transformer
- 6 instrument voltage transformer
- 7 cable terminal
- 8 outlet short-circuiting device
- 9 bus-bar short-circuiting device

CIRCUIT BREAKER

The circuit breaker consists of three separate one-pole encapsulated units which are mounted on a common basic frame. The conception is characterized by vertical location of the circuit breaker while the current-conductive path can create a fold "U" or "Z". On fig. 2 there is a section through circuit breaker with current-conductive path "U".

CIRCUIT BREAKER

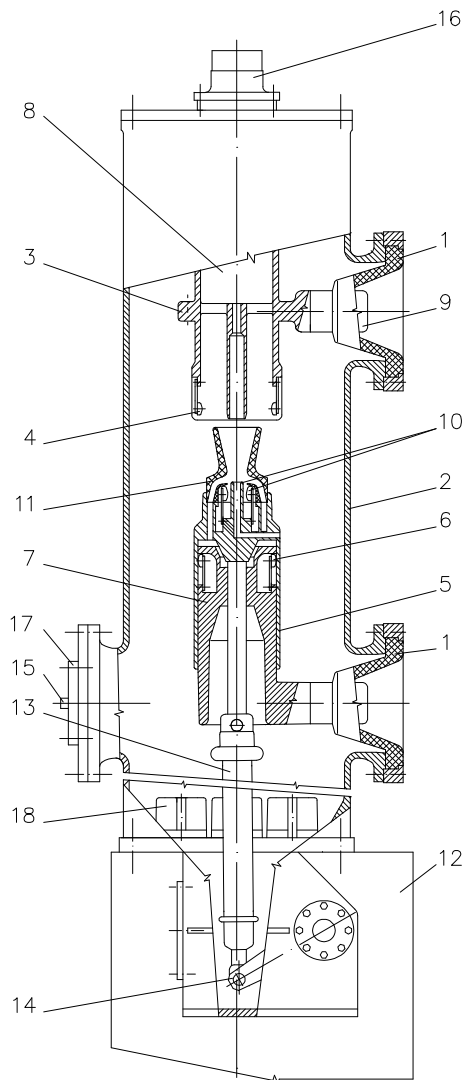

- 1 epoxide insulator
- 2 casing of circuit breaker
- 3 upper contact body
- 4 rose contact
- 5 movable cylinder
- 6 transmitting contact
- 7 lower contact body
- 9 push-on contacts
- 10 burning contact system
- 11 extinguishing jet
- 12 storage drive
- 13 insulating draw bar
- 14 control lever
- 15 filling valve
- 16 safety membrane
- 17 compensated scanner of SF₆ pressure
- 18 regeneration filter

DISCONNECTOR

The disconnector is constructionally solved with one-pole motor drive. It has a remote control or is controlled from place. The disconnector can be mounted in arbitrary position and according to use in field of the switchgear we distinguish an outlet and a bus-bar disconnector.

ANGULAR DISCONNECTOR

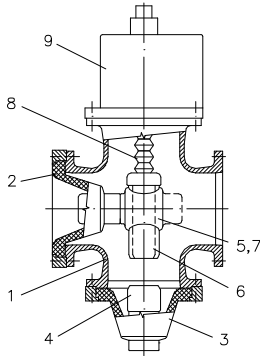

- 1 casing
- 2,3 insulator with embedding
- 4 fixed contact
- 5 body of disconnector
- 6 movable pin
- 7 push-on contacts
- 8 insulating draw bar with a screw
- 9 drive box

The drive box contains an electromotor with a gearbox, chain drives, coupling and signal contacts. The mechanical indicator of disconnector state is also located on the drive box. After dismantling the drive the control of the disconnector is electrically blocked, the access to the manual control of the drive is electrically blocked too. The drive shaft can be mechanically secured by the lock. The filling valve, safety membrane and thermally compensated gas pressure scanner are located on an independent cover while at bus-bar disconnector these devices are located in neighbouring casing.

At outlet disconnector the current-conductive path is in shape of "L", at bus-bar disconnector in shape of "T". On fig. 3 we can see the change of the body of outlet disconnector into bus-bar disconnector marked by dashed line. In some cases it is advantageous from point of view of switchgear disposition that the current-conductive path would create the letter "I". This condition is fulfilled by a direct disconnector. The description of this disconnector is analogous with the angular disconnector.

DIRECT DISCONNECTOR

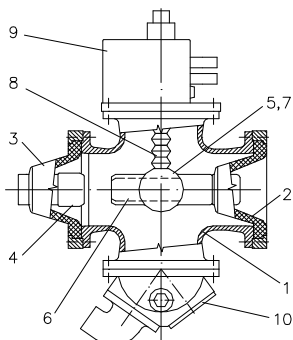

- 1 casing
- 2 insulator with embedding
- 3 insulator with embedding
- 4 fixed contact
- 5 body of disconnector
- 6 movable pin
- 7 push-on contacts
- 8 insulating draw bar
- 9 drive box
- 10 cover

SHORT-CIRCUITING DEVICE DISCONNECTOR

The short-circuiting device is solved for assembly on casing 1 and it can be performed as an separate device as it is perceptible from fig. 5 or it is mounted on the disconnecter. It is created by a separate switching unit 3. The shaft, lever mechanism with switching pin 4, driving spring, pneumatic damper and contact system is located in the body of the short-circuiting device. The fixed contact 5 is fixed on the insulator 6 in the casing 1. The motor storage drive with electromagnetic release with possibility of remote control, the manual drive with electromagnetic release and the driving unit for manual switching with which the device is working as a work earthing device can be mounted according to requirement on the body of the short-circuiting device. The execution of the short-circuiting device with motor storage drive and electromagnetic release are equipped with emergency manual control. At all executions it is possible to lock the device in earthed position.

The short-circuiting device serves to earth the parts of the electrical equipment and so safeguards the security of the operator during the revision works.

SHORT-CIRCUITING DEVICE

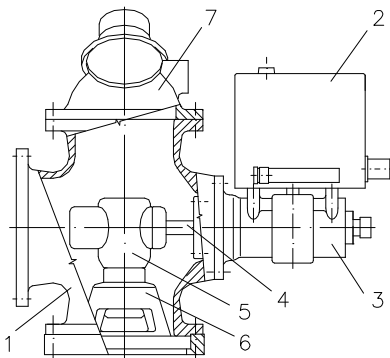

- 1 casing of short-circuiting device
- 2 storage drive
- 3 switching unit
- 4 movable pin
- 5 fixed contact
- 6 insulator
- 7 cover with devices

INSTRUMENT VOLTAGE TRANSFORMER

Max. system voltage	kV	110
Insulating voltage	kV	123
Testing AC voltage	kV/1 min.	230
Testing impulse voltage 1,2/50	kV	550
Rated frequency	Hz	50
Rated ratio	kV	$110\sqrt{3}/0,1/\sqrt{3}/0,1/3$
Rated load	VA	75/50
Class of accuracy		0,3/3P
Work overpressure of SF ₆ gas	MPa	0,35

The instrument voltage transformer with inside insulation of gas SF₆ contains three basic parts:

cover with accessories 1; casing of transformer 2; insulator with contact system 3.

The single instruments voltage transformer 4, fixed by screws to the risers on the inside part of the cover forms the accessories of this cover.

The instrument voltage transformer is one-pole insulated, it is the core type. The cylindrical secondary, auxiliary and primary windings are co-axially pushed on the core of the magnetic circuit with section of step polygon.

The secondary and auxiliary windings (6) from insulated copper conductor are wound commonly on one insulating casing, the primary winding (7) from insulated copper conductor is wound on an independent insulating casing.

Each beginning and end of the secondary and auxiliary winding is connected on an independent terminal connector in the secondary terminal board (8) which is fixed on one of the outside risers of the cover and is protected with sealable covering. The beginning of the primary winding is connected to an independent terminal connector of the secondary terminal board. The inside earthing terminal connector is also located in the secondary terminal board. The earthing of the transformers can be also done by means of an outside earthing terminal connector (9).

The markation of the terminal connectors in the secondary terminal board is the following:

secondary winding	a, n
auxiliary winding	da, dn
beginning of the primary winding	N
Inside earthing terminal connector	

According to customer wishes the instrument voltage transformers can be delivered with two secondary windings and one auxiliary winding. Their loads, voltages and classes of accuracy is necessary to negotiate with manufacturer.

Note: The markation of the terminal connectors is according to IEC 186.

During the service the terminal connectors marked with letters n, N must be connected by a flat connector marked with earthing mark. At disconnection of the flat connector the insulation of the primary winding can be tested against parts on the potential of the earth.

The end of the primary winding is connected to the primary terminal connector which is located on the outside perimeter of the primary winding are equipped with auxiliary electrodes 10; with aim to control the electrical field.

Also safety burst membrane with deflector 11, thermally compensated pressure scanner 12 and filling valve 13 pertain to the accessories located on outside risers of the cover.

The transformers satisfy the standard ČSN 35 1360 "Instrument transformers" and IEC 186 "Instrument voltage transformers".

INSTRUMENT VOLTAGE TRANSFORMER

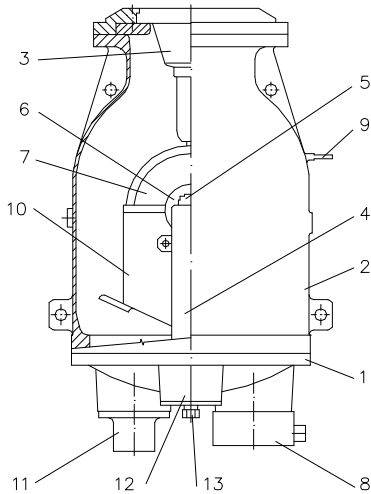

- 1 cover with accessories
- 2 transformer casing
- 3 insulator with contact system
- 4 instrument transformer
- 5 magnetic circuit
- 6 secondary and auxiliary winding
- 7 primary winding
- 8 secondary terminal board
- 9 earthing terminal connector
- 10 electrodes
- 11 membrane with deflector
- 12 gas pressure scanner
- 13 filling valve

INSTRUMENT CURRENT TRANSFORMER FOR ENCAPSULATION

Max. system voltage	kV	110
Insulating voltage	kV	123
Testing AC voltage	kV/1 min.	230
Testing impulse voltage 1,2/50	kV	550
Rated frequency	Hz	50
Rated primary current	A	150 – 2500 A
Rated secondary current	A	5 or 1
Rated load	VA	15 – 30; 30 – 60
Class of accuracy		0,2 – 0,5/5P10
Overcurrent number		< 5
Work overpressure of SF ₆ gas	MPa	0,35

The encapsulated instrument current transformer is one-purpose device which can be operated without further arrangement only in the system of the encapsulated switchgear with insulating voltage of 123 kV insulated with SF₆ gas. It serves for feeding protecting and measuring devices.

It has two basic parts: encapsulation 1; casting of instrument transformer 2; The transformer encapsulation consists of 4 parts - two flanges (3, 4), casing (5) and reduction (6).

The embedding of instrument transformer is screwed on one flange and this whole is fixed to the casing by means of the second flange. This flange has orifices which enable to connect the

transformer in the encapsulated switchgear. The reduction has the same function. The casing of cylindrical shape has a riser on its outside part in which the outside secondary terminal board (7) is located. The gland bushing determined for inlets from the secondary terminal board to the devices is located on the riser. The secondary terminal board is protected with a cover.

The casting of the instrument current transformer is of pushon execution with two magnetic circuits (8). Each of both magnetic circuits is individually closed into the casing for eliminating the danger of effect of mechanical forces on magnetic circuits by which the magnetic characteristics of used magnetic materials deteriorate substantially. The distance wedges from epoxy resin are risered on encapsulated magnetic circuits equipped with secondary winding; these wedges serve to fix the magnetic circuits with winding in casting mould and these circuits are filled with epoxy resin.

After rivering the both magnetic circuits with winding create a compact undismantled whole in shape of a hollow cylinder. The inside secondary terminal board is located on one front side, the nuts for fixing the transformer to the flange are embedded on the second front side. The cylindrical electrode (9) is located in the space between the casting of the transformer and the reduction for controlling the electrical field.

The terminal connectors both on inside and on outside terminal board are marked with letters 1S1, 1S2, 2S1, 2S2. The marking of the terminal connectors mentioned is according to IEC 185.

The transformers comply with the standard ČSN 35 1360 "Instrument transformers" and IEC 185 "Instrument current transformers" by their execution.

INSTRUMENT CURRENT TRANSFORMER FOR ENCAPSULATION

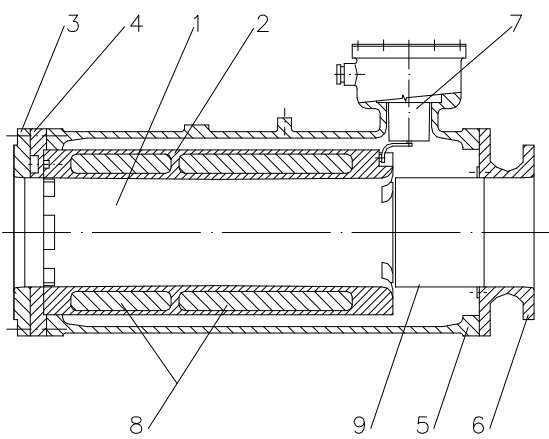

- 1 encapsulation
- 2 casting of instrument current transformer
- 3,4 flange
- 5 casing
- 6 reduction
- 7 secondary terminal board
- 8 magnetic circuit
- 9 electrode

CONNECTION OF THE SWITCHGEAR

One-core e.h.v. cable with cable ending in required parameters or outside outlet with bushing SF₆/air are considered for connection of the encapsulated switchgear ZRNG.

One-pole encapsulated cable terminal is composed of one-core e.h.v. cable 1 with ending; casing of cable terminal 2 and insulator 3 in which the plug-in contact is located. The insulator is equipped with transversal orifices that enables to connect a space of cable terminal with a neighbouring gas space.

CABLE TERMINAL

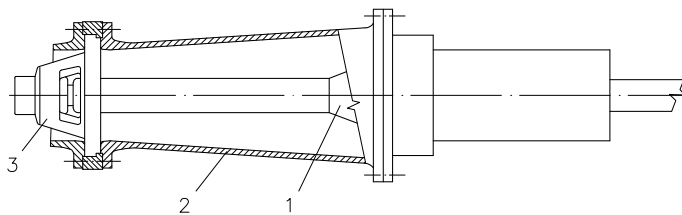

- 1 cable
- 2 encapsulation
- 3 insulator

OUTSIDE OUTLET

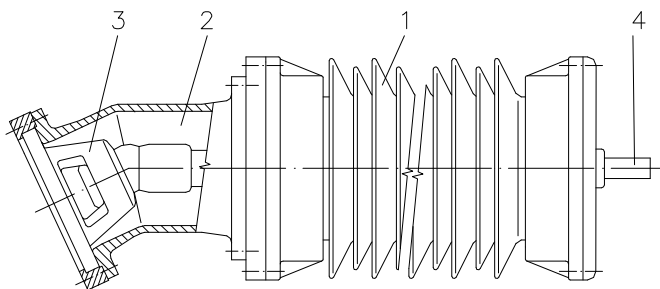

- 1 outside insulator
- 2 encapsulation
- 3 insulator
- 4 connecting pin

It is necessary to mention also the firm from which is supposed the delivery of e.h.v. cables including their endings (if they are used) at specification of the switchgear for order so that it would be possible to design and to test in time the pertinent encapsulation for the cable terminal.

The encapsulated line 3, ended with bushing SF₆/oil 4 placed in encapsulation 1 can be a further connection of the encapsulated switchgear directly to some type of power transformers. The axial compensators (stainless steel belows) 2 are inserted in the encapsulated line for limiting thermal dilatations and dimensional adaption.

CONNECTION OF POWER TRANSFORMER

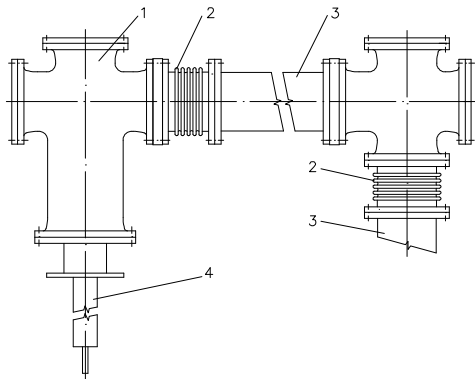

- 1 casing of bushing
- 2 axial compensator (stainless steel bellow)
- 3 encapsulated line
- 4 bushing SF₆/oil

BUS - BARS

The system of bus-bars illustrated is located in upper or lower part of the encapsulated switchgear field in dependence of connection mode, i.e. by cable, outside outlet or encapsulated line.

The conductors of the bus-bars 5 are one-pole encapsulated into cylindrical casings 3, 4. The bus-bar disconnector 1 the transversal conical insulator 7 of which divides the bus-bars on gastight sections in separate switchgear fields is built-in in each field into the bus-bar system.

The current-conductive path of the bus-bars is created by copper tube conductors 5 introduced by both ends in slide-in contacts. These contacts are located partly in the insulator of the bus-bar connector 7, partly in the body of the disconnector 8. Each bus-bar part is equipped with protection against inside failures 2, 6 and with filling valve which are common also for bus-bar disconnector.

After withdrawal of end covers the bus-bar system is prepared without further arrangements for connection of a further field during eventual expansion of already installed encapsulated switchgear.

BUS - BARS

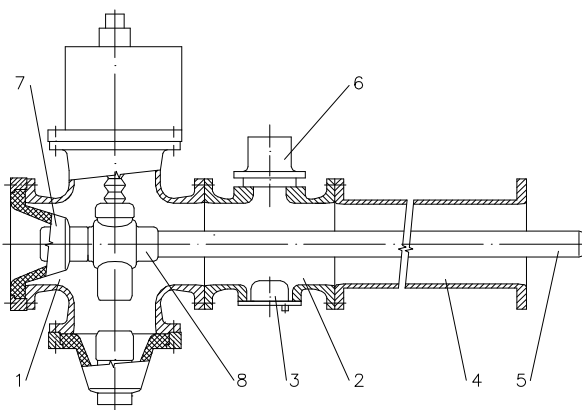

- | | |
|------------------------|--------------------------|
| 1 odpojovač | 1 disconnector |
| 2 pouzdro s vývody | 2 casing with outlets |
| 3 hlídač hustoty plynu | 3 scanner of gas density |
| 4 pouzdro přípojnice | 4 bus-bar casing |
| 5 vodič přípojnice | 5 bus-bar conductor |
| 6 průtržná membrána | 6 burst membráně |
| 7 příčný izolátor | 7 transversal izolátor |
| 8 těleso odpojovače | 8 disconnector body |

The connecting parts are necessary for assembly of the encapsulated switchgear field according to required scheme. These connecting parts ensure mechanical as well as electrical connection among devices. There are cylindrical casings of different length which are usually connected with a cross casing. A copper conductor of necessary length is led in the-ir longitudinal axis. The position of these conductors is ensured by a conical insulator of separate devices, e.g. circuit breakers and disconnectors, the electrical connection with the devices is carried out by push-in contacts.

The protections against inside failures and filling valves are usually common with the device on which they are fastened.

CONTROL BOX

Control boxes form part of the electrical equipment of the encapsulated switchgear. They serve to control the power parts of the encapsulated switchgear and to safeguard the communication among control systems by a supervision.

Main functions of control boxes

- distribution and protection of small voltages for needs of control and signalling
- evaluation of information about pressure and insulating states
- signalling of failures
- measuring of current states and feeding voltages
- electrical blocking of unpermitted switching operations
- basic control of field
- switching evaluated by logic of frame protection

The connection of the control box with devices in pertinent field is carried out according to schemes processed for concrete order. There is a scheme of a division of gastight parts of the switchgear illustrated on figure. Each field of the switchgear is equipped with the control box. The cables of auxiliary circuits of circuit breakers, disconnectors and short-circuiting devices ended with multipole plugs are connected into the box into the sockets which are located in both sides of the box.

The cables of pressure scanners and transformers of frame protection are connected by three-pole connectors on a frame insert. The connecting terminal boards for instrument transformers and auxiliary cables into neighbouring fields are located also on the frame insert in the lower part of the box.

Ready cables ended by multipole connectors form part of the delivery and their assembly on site is quite easy and rapid. The control boxes are mounted outside of the switchgear chassis in the hall of the substation face to separate fields. For orientation the control box is equipped by a blind scheme with position indicators.

TESTS IN IVEP

The parameters and executions of the encapsulated switchgear ZRNG satisfy the requirements of pertinent standards ČSN and IEC. The technical parameters were verified in the test rooms of IVEP Brno and by synthetic tests in the short-circuit testing station of joint-stock company Testing-Běchovice. The encapsulated switchgear satisfies the standard ČSN IEC 517 (35 7190) - "Metalically encapsulated gas insulated switchgears for rated voltages of 72.5 kV and higher" as well as the standard ČSN 35 4205 (eqv. to IEC 694-1980) - Switching devices and switchgears above 1000 V - Common regulations.

The devices were verified according to pertinent subjekt standard ČSN 35 4220 (eqv. IEC 56-1987) - "H.v. and e. h. v. a. c. circuit breakers, ČSN 35 4210 (eqv. to IEC 129-1984) - "A. c. disconnectors and earthing switches" and ČSN 35 1360 (eqv. to IEC 185, 186 - 1987) "Instrument current and voltage transformers".

The encapsulated switchgear except standard testing sequences satisfy at breaking a near short-circuit and at breaking unloaded outdoor and cable lines.

ASSEMBLY AND TESTS OF SWITCHGEAR ON SITE

The switchgear is sent to the place of destination in so called transport units dependent on concrete configuration of the switchgear. The transported units are filled by a gas SF6 on overpressure of 20 kPa. If they do not contain insulating elements they are equipped with auxiliary covers and they are transported without gas. The switchgear can be transported by usual means according to agreement between the producer and the customer. The switchgear must be stored in a building in an environment corresponding to climatic resistance N3 according to ČSN 03 8805.

The assembly of the switchgear including the connection of control and signalling cables into the control box is carried out by the producer, if need be after agreement with the customer the producer will assist at the total assembly done by the customer. The assembly is carried out only in quite constructionally finished buildings so that the max.dustiness of 1 mg of dust on 1 cubic meter of air would be ensured.

The hall must be equipped with a crane with min. loading capacity of 1,500 kg. The assembly consists in composition of the power part of the switchgear (connection of transport units), connection of signal, control and protection and interconnection of control boxes. The connection of lines for measuring and remote control and signal circuits will be ensured by the customer. Also the ending and testing of 110 kV power cables is not carried out by the producer of the switchgear. These works must be ordered at the producer of cables. The gas N2 is blown off from separate gastight sections of the switchgear after the assembly and these parts are filled with pure gas SF6 with pressure 0.45 MPa at 20°C on a

prescribed pressure according to special regulations.

The manipulation with SF6 is realized by so called operating station which enables vacuum degassing, drying and filling of separate spaces. This station is not necessary for the switchgear performance, contingent gas leakage can be completed directly from a pressure bottle equipped with a reduction valve. This bottle forms part of switchgear delivery.

After assembly before putting into service the gas insulated metalically encapsulated switchgears must be tested for ensuring the reliability and safety in service, the correct function and dieletrical strength of the device must be checked. These tests are carried out with regard to the possibility of damage during transport, quality of assembly and correctness of connection. The tests are carried out according to ČSN IEC 517(35 7190) - "Metalically encapsulated gas insulated switchgears for rated voltages of 72.5 kV and higher".

These tests and checks contain:

- voltage tests of electrical strength of insulation of main circuits
- insulating tests of control and auxiliary circuits
- measuring of main circuits resistance
- test of gas leakage
- inspections and checks
- measurement of gas state

MAINTENANCE AND REVISION

The switchgear does not claim a maintenance, the drives of breaking dewices, where it is necessary to complete a lubricant in prescribed intervals, form an exception. The time to the 1st revision is 10 years. This time is minimum and after these 10 years on the basis of appreciation of the technical state it can be prolonged up to double. The revision is done by the producer who will consider the possibility to prolong the service. The time will be prolonged if the following number of functions will not be reached at the switching devices.

- Circuit breaker 2,000xOC or breaking 30x rated breaking current (in total 900 kA)
- Disconnecter 2,000xOC
- Short-circuiting device 2,000xOC and 10x making into shortcircuit

EXAMPLES OF LAYOUT SOLUTION

On pictures we can see the layout solution of unusual connections. The high variability however enables almost arbitrary layout of different connections, e.g. a so called connection with separate phases, connection with more circuit breakers on a tapping, execution with 3 systems of busbars, if need be auxiliary bus-bar, etc. according to customer's wish.

FIELD WITH CABLE INLET

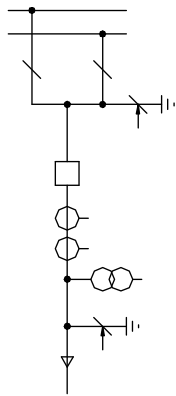

šířka pole: 1500 mm
width of pole: 1500 mm

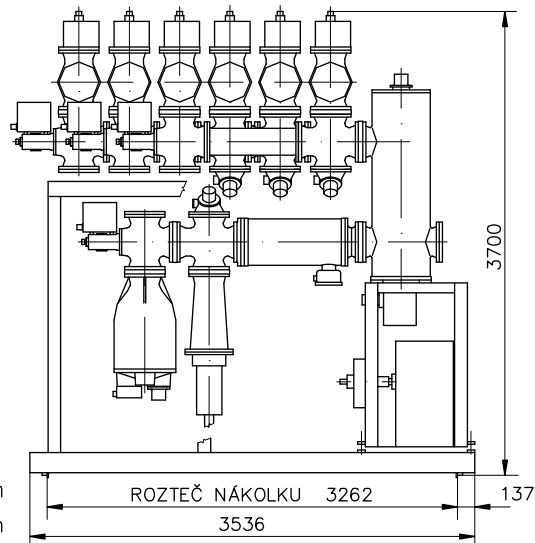

FIELD OF SWITCH OF BUS BARS

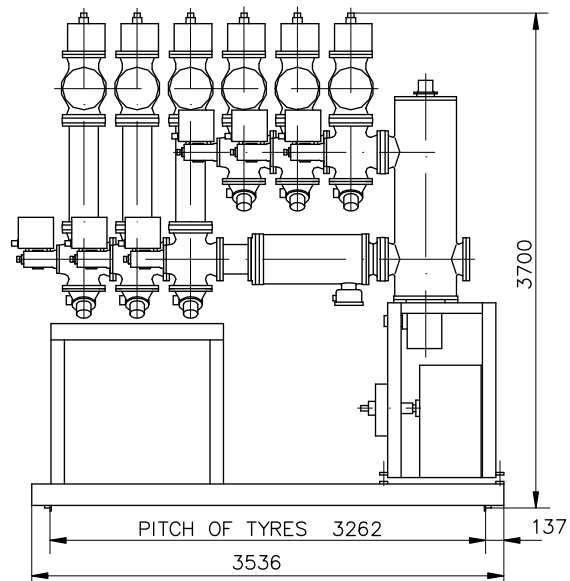
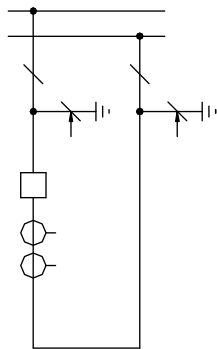

FIELD WITH ENCAPSULATED OUTLET TO TRANSFORMER

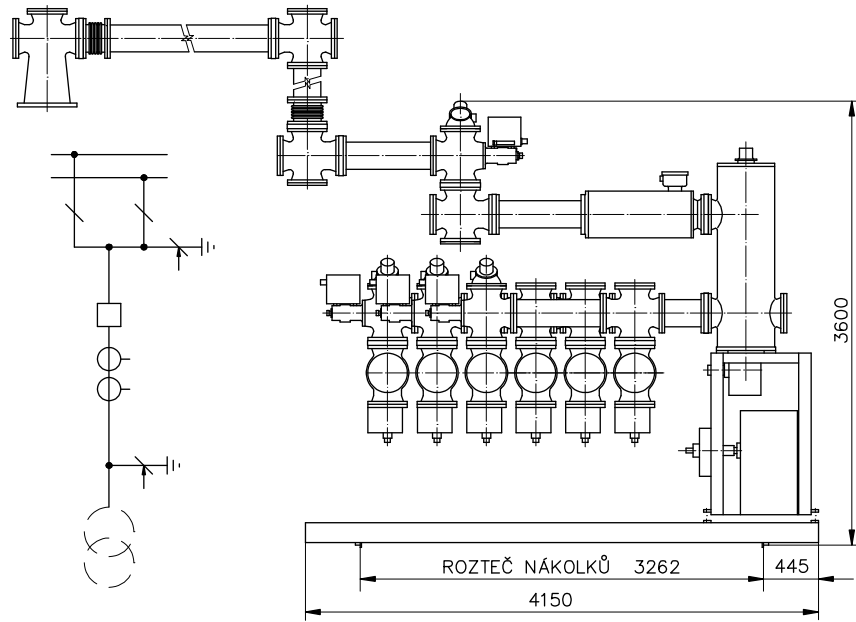

FIELD WITH OUTSIDE OUTLET

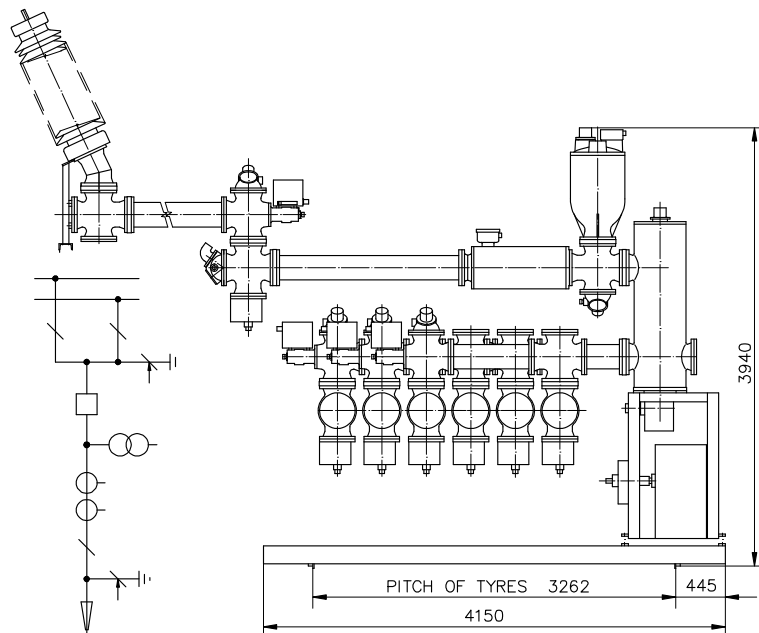



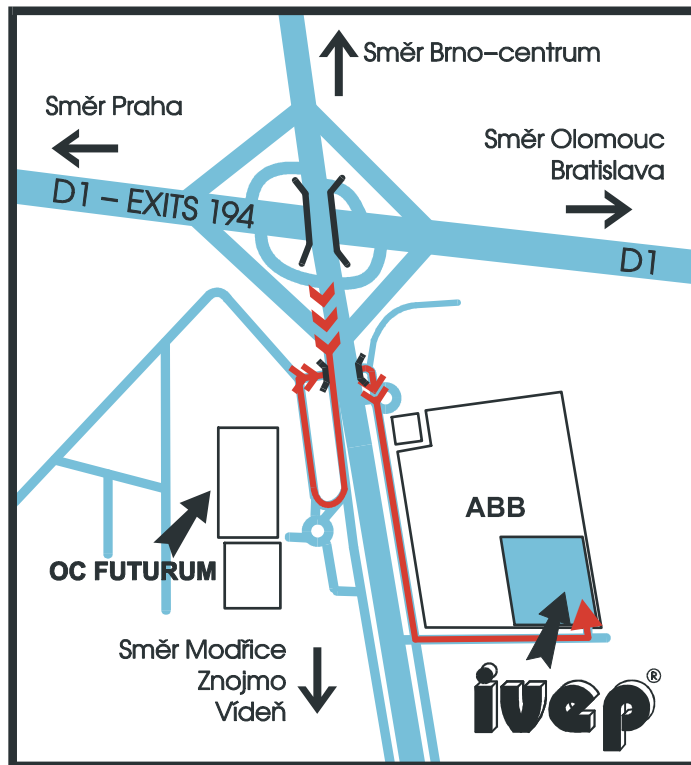

Domänenstr. 38
44225 Dortmund

Telefon: +49 (0) 231 - 72 73 865
Mobil: +49 (0) 174 - 59 55 755

E-mail: sales@tetrado.de
Web: www.tetrado.de

Manufactured and supplied by:

IVEP, a.s.
Vídeňská 117a, 619 00 Brno, Czech Republic

Tel.: +420 547136 654 e-mail: marketing@ivep.cz
Fax: +420 547136 402 [http:// www.ivep.cz](http://www.ivep.cz)

